

PAINT BORER 518 MC

1

---

**Read this Operating Manual carefully before putting the instrument into operation.**

## Operating Instructions

### Thickness Gauge PAINT BORER 518 MC

**Country of origin:** Germany

**Status:** VI/2012

---

BAE 518 MC



**ERICHSEN**  
since 1910

| <b><u>Index</u></b>                      | <b><u>Page</u></b> |
|--|--------------------|
| <b>1 Fundamentals</b>                    | <b>3</b>           |
| 1.1 Receiving Inspection                 | 3                  |
| 1.2 Purpose and Designated Use           | 3                  |
| 1.3 Storage and Operation                | 3                  |
| 1.4 Safety Instructions                  | 3                  |
| 1.5 Copyright                            | 3                  |
| 1.6 Address of the Supplier              | 3                  |
| <b>2 Instrument Data</b>                 | <b>4</b>           |
| 2.1 Name / Type                          | 4                  |
| 2.2 Scope of Supply                      | 4                  |
| 2.2.1 Basic instrument                   | 4                  |
| 2.2.2 Additional accessories (optional)  | 4                  |
| 2.2.3 Spare part                         | 4                  |
| 2.3 Technical Data                       | 5                  |
| 2.3.1 Basic instrument                   | 5                  |
| 2.3.2 Drills                             | 5                  |
| 2.3.3 Specimen Platform                  | 5                  |
| <b>3 Operation – Function - Handling</b> | <b>6</b>           |
| 3.1 Power Supply                         | 7                  |
| 3.2 Illumination                         | 7                  |
| 3.3 Sliding Mechanism                    | 7                  |
| 3.4 Measuring microscope                 | 8                  |
| 3.5 Drills (Wedge cut method)            | 8                  |
| 3.6 Specimen Platform                    | 9                  |
| <b>4 Layer Thickness Measurement</b>     | <b>10</b>          |
| 4.1 Specimen preparation                 | 10                 |
| 4.2 Drilling Procedure                   | 10                 |
| 4.3 Establishing the Coating Thickness   | 11                 |
| <b>5 Special Measuring Problems</b>      | <b>13</b>          |
| 5.1 Peeling                              | 13                 |
| 5.2 Curved Surfaces                      | 14                 |
| 5.3 Specimen Tilting                     | 14                 |
| 5.4 Literature                           | 15                 |
| <b>6 Maintenance and Care</b>            | <b>16</b>          |

---

## 1 Fundamentals

### 1.1 Receiving Inspection

Check delivery for completeness. Transport damages should be documented and reported directly to the supplier or the relevant insurer.

### 1.2 Purpose and Designated Use

The **PAINT BORER 518 MC** is intended to measure the thickness of organic coatings on any substrates using the wedge cut method.

ERICHSEN GmbH & Co. KG will not be liable for damages resulting from improper use.

### 1.3 Storage and Operation

For the admissible climatic conditions please refer to chapter 2.3.1.

### 1.4 Safety Instructions

The general statutory as well as otherwise binding regulations for accident prevention and environmental protection have to be observed.

### 1.5 Copyright

The copyright of this instruction manual remains with ERICHSEN GmbH & Co. KG, D-58675 Hemer. The instruction manual is intended solely for the user and his personnel.

The instruction manual contains instructions and guidelines which may not be duplicated, distributed or otherwise passed on to others either in full or in part. Infringement of these restrictions can lead to legal action.

### 1.6 Address of the Supplier

**ERICHSEN GmbH & Co. KG**  
**Am Iserbach 14**  
**D-58675 HEMER / Germany**

Tel.: (02372) 9683-0  
Fax: (02372) 6430  
eMail: [info@erichsen.de](mailto:info@erichsen.de)  
Internet: <http://www.erichsen.de>

## 2 Instrument Data

### 2.1 Name / Type

**Thickness Gauge PAINT BORER, Model 518 MC ,**  
Ord.-No. 0283.03.31, with microscope to be turned and moved sideways



### 2.2 Scope of Supply

#### 2.2.1 Basic instrument

- 1 Drill No. 5 for layer thicknesses up to 300 microns
- 1 Felt test pen black
- 1 Felt test pen silver
- 1 Screw driver
- 1 Rechargeable battery (9 V)
- 1 Power pack (100 – 240) VAC / (47 – 63) Hz
- 1 Operating Instructions
- 1 Plastic case

#### 2.2.2 Additional accessories (optional)

|  |                     |
|--|---------------------|
| Drill No. 2 for layer thicknesses up to 200 microns  | Ord.-No. 910927241  |
| Drill No. 4 for layer thicknesses up to 500 microns  | Ord.-No. 910927741  |
| Drill No. 3 for layer thicknesses up to 1000 microns | Ord.-No. 910927841  |
| Drill No. 1 for layer thicknesses up to 1000 microns | Ord.-No. 910927141  |
| Specimen platform                                    | Ord.-No. 0326.01.32 |

#### 2.2.3 Spare part

|   |                    |
|---|--------------------|
| Drill No. 5 for layer thicknesses up to 300 microns | Ord.-No. 910928241 |
|---|--------------------|

## 2.3 Technical Data

### 2.3.1 Basic instrument

|                                    |   |
|------------------------------------|---|
| Dimensions (H x W x D)             | 110 mm x 55 mm x 145 mm                         |
| Net weight                         | approx. 800 g                                   |
| Number of revolutions of the drill | approx. 180 rpm                                 |
| Minimum dimensions of specimen     | 150 mm x 25 mm                                  |
| Mains connection (alternative)     |   |
| - 9-V-Accu                         | 6F22  |
| - 9-V-Battery                      | 6LR61   |
| - Power pack                       | (100 – 240) VAC, (47 – 63) Hz<br>18 VDC / 0,8 A |
| Temperature range                  |   |
| - Storage conditions               | -10 °C bis +70 °C                               |
| - Operating conditions             | -10 °C bis +40 °C                               |

### 2.3.2 Drills

Table 1 Performance of the drills (wedge cut method)

| Drill                      | No. 2 <sup>1)</sup> | No. 5 <sup>2)</sup> | No. 4 <sup>1)</sup> | No. 3 <sup>1)</sup> | No. 1 <sup>1)</sup> |
|----------------------------|---------------------|---------------------|---------------------|---------------------|---------------------|
| Measuring range            | up to 200 µm        | up to 300 µm        | up to 500 µm        | up to 1000 µm       | up to 2000 µm       |
| Scale factor (f)           | 2 µm/sc.div.        | 3 µm/sc.div.        | 5 µm/sc.div.        | 10 µm/sc.div.       | 20 µm/sc.div.       |
| Cutting angle ( $\alpha$ ) | 5,7°                | 8,5°                | 14,0°               | 26.7°               | 45°                 |
| tan $\alpha$               | 0.10                | 0.15                | 0.25                | 0.50                | 1.0                 |
| Geometry                   | two-edges           |                     |                     |                     | single-edges        |
| Head-Ø                     | 5 mm                |                     |                     |                     |                     |
| Material                   | carbide             |                     |                     |                     |                     |

<sup>1)</sup> as accessory

<sup>2)</sup> included in the scope of supply

### 2.3.3 Specimen Platform

|                                |                        |
|--------------------------------|------------------------|
| Dimensions (H x W x D)         | 60 mm x 130 mm x 55 mm |
| Net weight                     | approx. 145 g          |
| Minimum dimensions of specimen | 10 mm x 6 mm           |
| Maximum width of specimen      | 73 mm                  |
| Maximum thickness of specimen  | 25 mm                  |

### 3 Operation – Function - Handling

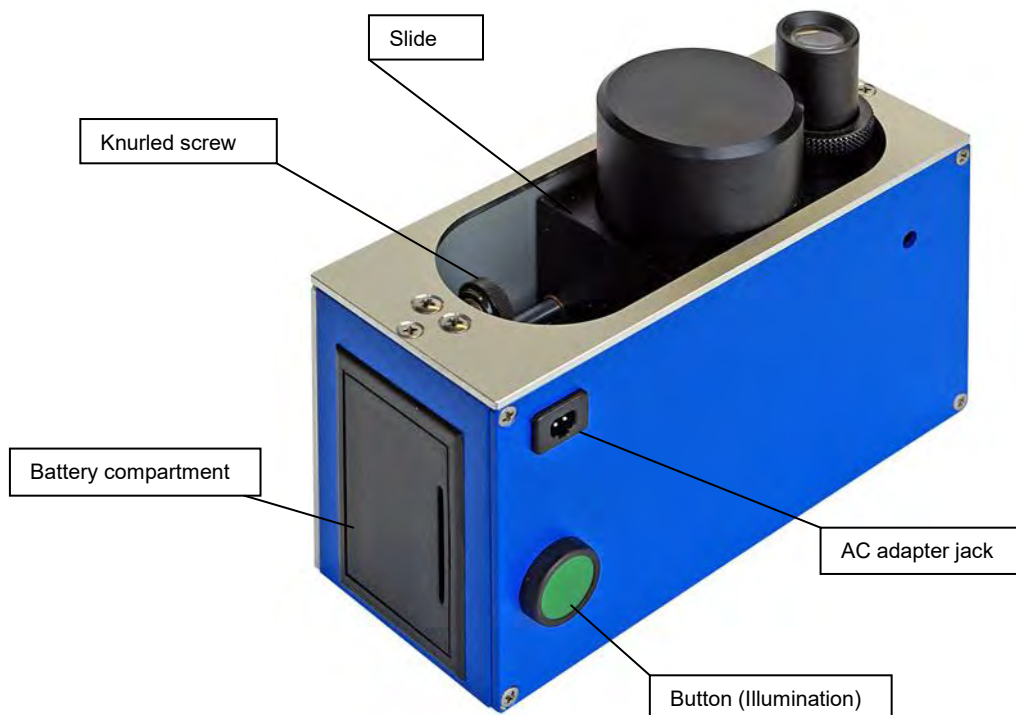

d

### 3.1 Power Supply

The **PAINT BORER 518 MC** is basically intended for use independently of the mains supply, i.e. it is a portable instrument. The built in power source is in the form of a 9 V NC rechargeable battery (IEC No. 6F22). Alternatively, a 9 V compact battery (alkaline manganese Type IEC No. 6LR61) can be employed.

The 9 V rechargeable battery is delivered packed separately and has to be inserted into the black plastic compartment on the right-hand side before the instrument is put into operation. Care is necessary to prevent breaking off the battery cable.



The jack for connecting the AC adapter is located on the rear of the **PAINT BORER**. The time required for charging is 14 hours. The instrument can be operated whilst it is charged.



Attention

If the **PAINT BORER** is operated with batteries, the charging unit must by no means be connected to it.



If the **PAINT BORER** is generally connected to the mains, it is advisable to remove the rechargeable battery as otherwise it will be overcharged. If the instrument is mainly connected to the mains supply, but is occasionally also used for mobile applications, the rechargeable battery may be left in the instrument, but the recharger should not always be connected.

### 3.2 Illumination

A white light emitting diode (LED) for diffuse light is used for sample illumination. The button for illumination is located on the rear of the **PAINT BORER**.

To switch on the LED press the button briefly. Press the button longer to switch off the LED, or wait for 60 s (shut down automatically). When switched on, the LED brightness can be varied in three steps. After switching on the middle step is always set.

### 3.3 Sliding Mechanism

An important part of the **PAINT BORER** is the slide which holds the drilling head and measuring microscope. The slide can be moved from side to side in such a way that in one end position the drill is above the test point and in the other end position the microscope is above the test point.

In the left-end position for drilling, the slide rests against a micro-switch. Slight pressure on the spring drill head suffices to move the drill downwards and simultaneously to switch on the motor.

The right-end position fixes the measuring point of the microscope. A horizontal screw with knurled plastic head is fitted on the right at the top of the frame for sensitive adjustment of this end position. Since the fine adjustment only acts in one direction (towards the left), the knurled screw should be screwed inward (towards the right) before each measurement is made.

The microscope can be moved across the slider and additionally also be rotated. A knurled ring for turning is mounted on the tube.

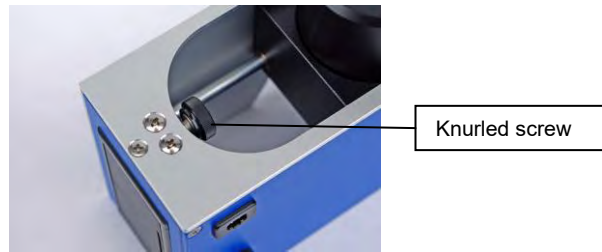

### 3.4 Measuring microscope

With the 100 division scale of the measuring microscope magnifying 50 times a measuring range covered by 2 mm. One mark of the scale corresponds to 20  $\mu\text{m}$ , and the measurement resolution is 1% of measuring range.

For the adjustment of the measuring microscope hold the knurled ring. With the light switched on, first turn the eye piece holder to bring it into focus with the measuring scale and then raise or lower the complete microscope tube to bring it into focus with the specimen surface.

### 3.5 Drills (Wedge cut method)

Part of the basic equipment of the **PAINT BORER** is a drill for a measuring range of 300 microns (drill no. 5). Further drills for measuring ranges of 200 microns (drill no. 2), 500 microns (drill no. 4), 1000  $\mu\text{m}$  (drill no. 3) and 2000  $\mu\text{m}$  (drill no. 1) can be supplied as accessories.

The drill no. 1 employs a single cutting edge, but the drills no. 2, 3, 4 and no. 5 are fitted with two cutting edges so as to achieve a good conical shape in spite of the shallow angle (5.7°, 8.5°, 14° or 26.7°).

All drills are entirely made of carbide. This means that they are extremely resistant to abrasion and wear but also extremely brittle. The drills must therefore not be submitted to any excessive knocking especially when working with hard substrates.

To change the drill slacken the clamping screw within the holding fixture using the supplied screw driver and remove the drill. Insert the new drill in such a way that it locks into the coupling and then tighten the clamping screw.



### 3.6 Specimen Platform

The specimen platform available as an accessory, is intended to serve as an clamping adapter for small parts (e. g. parts cut from larger specimens) and for (slightly) curved specimens as well as for specimens with a complicated geometry (e. g. shaped parts).

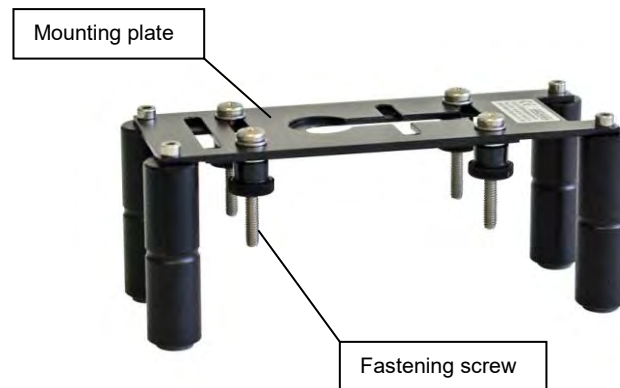

Slots are milled into the mounting plate of the specimen platform. These in conjunction with two rails with holes provide sufficient degrees of freedom for fixing specimens various geometrical shapes. When clamping the specimen take care that the mounting plate is not bent.

The rails with holes are intended to serve only as basic equipment: If series of measurements are to be performed on specimens of similar shape and dimensions, it is recommended to employ specially made clamping pieces, for example of bent sheet metal strip, matched in an optimum manner to the geometry of the specimen to facilitate more rapid measurement.

The mounting plate is constructed in such a way that it can be fixed underneath the **PAINT BORER** and the latter can then be placed onto the round feet of the specimen table. This will ensure that the specimens - with or without specimen platform - are always drilled in the same manner.



---

## 4 Layer Thickness Measurement

### 4.1 Specimen preparation

Initially select a flat part of the specimen surface. The area must be large enough for the rubber supports on the sides of the **PAINT BORER** to be well supported. Unless special additional measures are taken this means that the minimum specimen dimensions are 150 x 25 mm. Use the specimen table for smaller samples (see section 3.6).

A contrast mark should be applied at the test point covering a minimum area of 6 mm diameter. The colour of this mark should be in the strongest possible contrast with the colour of the specimen surface so as to make it easier to measure the cut through the coating with the microscope.

For light coloured specimens the black felt tip pen supplied can be used for the contrast mark; for dark coatings use the silver felt tip pen for marking (only apply a thin layer and let it harden sufficiently).

It is useful to adjust the microscope before drilling of the specimen (see section 3.4). The easiest way is to focus onto the edge of the contrast mark on the specimen surface.

### 4.2 Drilling Procedure

Set up drill for desired measuring range into the drilling head and fix.

If the layer thickness is not known, initially use a drill with a large angle and select optimum angle on this basis.

In case of multi layer systems where drills of different angles are to be employed, start with a drill with larger angle to bring the full section into view. The upper layer can then be drilled with another drill with smaller angles for higher accuracy in a separate operation.

Place slide of **PAINT BORER** against left location measuring instrument onto specimen so that drill tip is approx. in the centre of the contrast mark.

By slightly pressing on drilling head initiate drilling process. This should be done sensitively, to regulate the rate of cutting to suit the layer system and it may have to be optimised by trial.

It is essential to drill just into the substrate. The tips of the drills are designed so that they can be allowed to cut into the substrate by up to  $\frac{1}{4}$  of the measuring range without limiting the measuring range.

### 4.3 Establishing the Coating Thickness

After drilling, move slide piece of **PAINT BORER** to right hand end position to bring the microscope over the hole. Switch on lamp (see 3.2) and adjust focus if necessary.

It will now be possible to see through the microscope a number of concentric circles in accordance with the number of layers. The distance between the circles (see figure 1), i. e. the difference in radius, should now be measured.

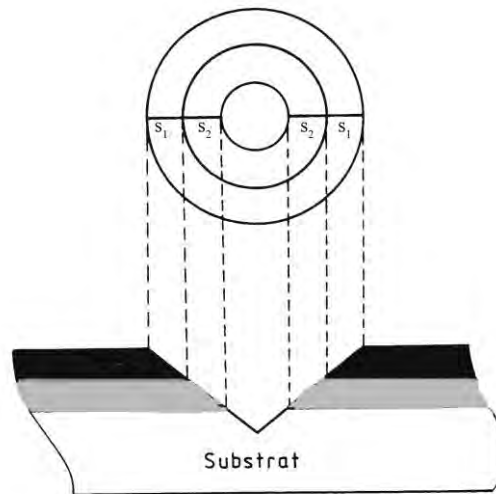

Fig. 1: Drilled hole of a two-layer coating shown in cross section and observed with microscope ( $s_1 / s_2 =$  Measuring distance for layers 1 / 2)

Carefully move slide carrying microscope to the left by turning the knurled screw so that the start of the measuring scale is in line with one end of the distance to be measured as shown in Fig. 2.

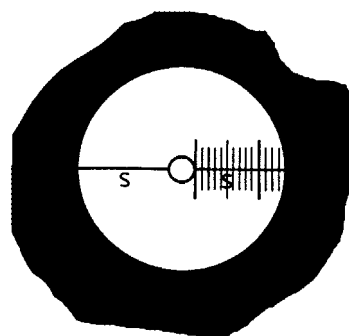

Fig. 2: Measurement of a film section consisting of a single layer using microscope  
Single coating ( $s =$  measuring distance)

A fundamental rule is to take advantage of the symmetry of the cut out and make measurements on diametrically opposed sides for evaluation (see Fig. 2).

Count number of scale divisions **s** and multiply by the relevant scale factor **f**.  
The layer thickness **d** is given by:

$$\mathbf{d = s \times f \quad (1)}$$

in micron units, the factor **f** always being 1/100 of the measuring range.

In the same way also the thickness of individual layers can be determined. For this measure the individual "s"-values (see fig. 1, measuring distances **s<sub>1</sub>** and **s<sub>2</sub>**) and calculate in accordance with formula **(1)**.

The microscope evaluation is frequently not possible, if the coating material crumbles in the drilling zone so that the line of the cut layers is not circular but an irregular closed shape. In a few cases, however, the inner circle corresponding to the point where the coating touches the substrate is still just visible (dashed circle in Fig. 3) and measurement can therefore be made as previously described (measuring distance **s<sub>1</sub>** in Fig. 3).

## 5 Special Measuring Problems

### 5.1 Peeling

Brittle coatings and/or coatings with poor adhesion on the substrate often result in drilled cut outs on which the border between the coating and the substrate is not circular, i.e. has an irregular edge (see fig. 3).

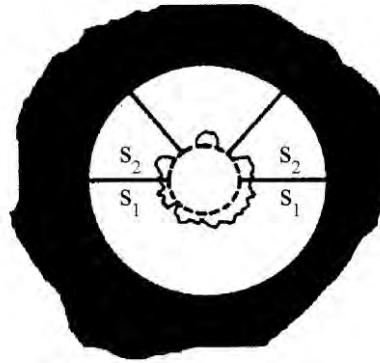

**Fig. 3: View through microscope onto drilled cut out with crumbled edges**  
( $s_1$  /  $s_2$  = measuring distances)

The normal microscopic evaluation would in such cases lead to incorrect low coating thickness values, since part of the measuring distance will be missing due to peeling off. If only part of the periphery has broken away, there will still be measuring distance available that corresponds to the true coating thickness (see  $s_2$  in Fig. 3) so that a correct evaluation will be possible.

In a few cases, however, the inner circle corresponding to the point where the coating touches the substrate is still just visible (dashed circle in Fig. 3) and measurement can therefore be made as previously described (measuring distance  $s_1$  in Fig. 3).

Several cuts should be drilled into the specimen and in each boring as many measurements as possible should be made. The longest measuring distance established in this way will then provide a good approximation to the true coating thickness.

There are additional measures that can be helpful in case of coatings with poor adhesion:

- The peeling effect is particularly drastic, when the tip of the drill just pierces the border between the coating and the substrate. Therefore it is recommended to cut as deeply as possible into the substrate.
- Always drill intermittently, never drill off the reel. Blow away the bore chips after each cut. The interrupted drilling is particularly essential in case of ductile substrate materials which tend to produce big chips (e.g. some types of plastics).
- The mechanic characteristics of soft plastics adverse to the spot drilling, may be optimised by cooling (freezer/freezing compartment or cooling spray). When using cooling spray cover the surface of the coating by an aluminium foil to protect it against solvent attacks.

## 5.2 Curved Surfaces

In principle the specimens should be plane so that the wedge cut bores can be accurately be evaluated. In case of curved specimens the layer thickness calculated with the help of an equation (1) is always thinner than the real coating thickness (deviation  $\Delta$ ).

For a predetermined maximum deviation  $\Delta_{\max}$  (in %) a minimum curvature radius  $\rho_{\min}$  (in m) can be estimated which depends on the layer thickness  $d$  (in microns) and the scale factor  $f$  (in microns/scale division):

$$\rho_{\min} = d / (5 \times \Delta_{\max} \times f^2) \quad (2)$$

Equation (2) signifies: If the curvature radius is greater than the limit radius  $\rho_{\min}$ , the curvature effect within an accuracy predetermined by  $\Delta_{\max}$  can be neglected and the layer thickness can be calculated by equation (1).

Example: For  $d = 100$  microns and  $f = 3$  microns/scale division (drill no. 5) the curvature radius must be greater than 0.44 m so that the deviation  $\Delta$  is smaller than 5 % when the layer thickness is calculated by equation (1).

## 5.3 Specimen Tilting

On specimens with small amounts of curvature it may easily happen that the drill will not be operated perpendicularly to the surface. The same situation arises with tests on small specimens of different shapes which cannot always be set up in the correct attitude under the specimen platform.

If the drill is not perpendicular to the specimen, drilling will be oblique. The image in the microscope will then be in the shape of ellipses offset relative to one another in place of concentric circles. The common major axis of the ellipses will not necessarily coincide with the sliding axis of the instrument (see fig. 4).

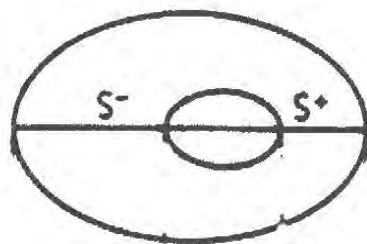

Fig. 4: View through microscope: specimen not drilled perpendicularly ( $s/s^+$  = measuring distance)

For evaluation it is necessary to determine first the offsets of the ellipses in the direction of the common principal axis ( $s^-$  und  $s^+$  in Abb. 4). Thereby all degrees of freedom for the measuring microscope offered by the **Paint Borer**, are required.

The layer thickness  $d$  (in microns) is then calculated using the measuring quantities  $s^-$  and  $s^+$  (in scale divisions) and with the scale factor  $f$  (in microns/scale division) of Table 1 according to

$$d = 0,1 \times ((s^- \times s^+) / (s^- + s^+)) \times f \quad (3)$$



**In no case it is permitted to calculate the film thickness according to  $s = ((s^- + s^+) / 2) \times f$  (arithmetic average)**

#### 5.4 Literature

A detailed dealing with all measuring problems that may occur using the wedge cut method can be found in DIN 50986 (at the moment a draft). This standard indicates also the mathematical deduction of the equations (2) and (3). In the standard instead of the scale factor  $f$  the wedge cut factor  $\tan \alpha$  is employed which is linked to  $f$  by the relation " $f = 20 \times \tan \alpha$ ".

## 6 Maintenance and Care

- The **PAINT BORER 518 MC** does't require any maintenance.
- If the instrument is very wet due to exposure, it must be allowed to dry out immediately to prevent corrosion of the slideaways and electric contacts.
- The tips of the carbide drills should regularly be inspected for wear or damage using a magnifying glass (magnification factor at least 10), and,if necessary, be exchanged.
- In case of technical problems please contact the manufacturer:

**ERICHSEN GmbH & Co. KG**  
**Am Iserbach 14**  
**D-58675 HEMER**

**Tel.: (02372) 9683-0**

**Fax: (02372) 6430**

**eMail: [info@erichsen.de](mailto:info@erichsen.de)**

**Internet: <http://www.erichsen.de>**

The right of technical modifications is reserved.



PAINT BORER 518 MC

17

## EG-Konformitätserklärung

### EG-Declaration of Conformity

Wir/We **ERICHSEN GmbH & Co. KG, Am Iserbach 14, 58675 Hemer**

erklären in alleiniger Verantwortung, dass das nachfolgend aufgeführte Produkt  
*declare under our sole responsibility that the product described below*

**Schichtdickenmessgerät PAINT BORER**  
**Thickness Measuring Instrument PAINT BORER**

Modell / Model: **518 MC**

- konform ist mit den Bestimmungen folgender Richtlinien:  
*- complies with the provisions of the following directives:*

**EMV-Richtlinie (2014/30/EU) – EMC Directive**  
**Niederspannungsrichtlinie (2014/35/EU) – Low Voltage Directive**

Angewandte Normen:  
*Applied Standards:*

**DIN EN 61000-6-2 (VDE 0839-6-2):2006-03**

Bevollmächtigter für die Zusammenstellung der technischen Unterlagen:  
*Agent for the compilation of technical documents:*

***Bettina Betzinger-Rabe (Technische Dokumentation)***

Hemer, 13.10.2015



.....  
ppa. **Stefan Schneider**  
Technischer Leiter/*Technical Director*

BAE 518 MC



**ERICHSEN**  
since 1910