

Digital Force Gauges Series 3



Series 3 digital force gauges are designed for tension and compression force testing in numerous applications from 0.12 lbf to 500 lbf (0.5 N to 2500 N). The gauges feature a sampling rate of 2,000 Hz, producing accurate results under a wide range of test conditions. A backlit graphic LCD displays large characters, and a menu is available to access the gauges' features and configurable parameters. USB output is provided for data collection purposes.

Set point indicators are provided for pass-fail testing. The gauges are overload protected to 150% of capacity, and an analog load bar is shown on the display for graphical representation of applied force.

An ergonomic, reversible aluminum housing allows for hand held use or test stand mounting for more sophisticated testing requirements. Series 3 digital force gauges are directly compatible with Mark-10 test stands, grips, and software.

The gauges include MESUR Lite data acquisition software. MESUR Lite tabulates continuous or single point data. One-click export to Excel allows for further data manipulation.



Shown with an ES20 test stand and G1061 wedge grips

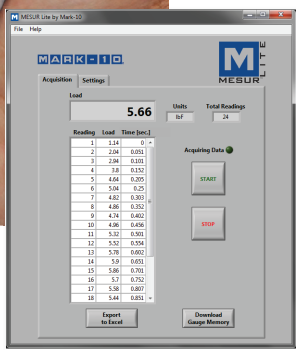

MESUR Lite data acquisition software is included with Series 3 gauges

Features

- High-speed 2,000 Hz sampling rate
- USB data output
- Ultra-compact size
- Large backlit graphic display
- Programmable set points with pass/fail indicators
- Live load bar graph with set point markers
- Peak readings and set points always displayed
- Configurable audio alarms and key tones
- 4 selectable units of measurement
- MESUR Lite data collection software included

Display Indicators



Focus on Engineering: Reversible Housing



Specifications

Accuracy:	±0.3% of full scale ±1 digit
Sampling Rate:	2,000 Hz
Power:	AC or rechargeable battery. Multi-step low battery indicator is displayed, gauge shuts off automatically when power is too low.
Battery life:	Backlight on: up to 7 hours of continuous use Backlight off: up to 24 hours of continuous use
Measurement Units:	lbF, gF, kgF, N (depending on model)
USB Output:	By pressing DATA key only. Configurable up to 115,200 baud.
Configurable settings:	Digital filters, USB output, automatic shutoff, default settings, key tones, audio alarms, calibration.
Safe overload:	150% of full scale (display shows "OVER" at 110% and above)
Weight (gauge only):	M3-012 - M3-100: 0.7 lb [0.33 kg] M3-200 - M3-500: 0.9 lb [0.41 kg]
Load cell deflection:	All models 0.010 [0.25], except 0.050 [0.13] for M3-012
Included items:	Carrying case with chisel, cone, V-groove, hook, flat, extension rod, universal voltage AC adapter, battery, quick-start guide, USB cable, resource CD (USB driver, MESUR Lite software, MESURgauge DEMO software, and user's guide), and NIST-traceable certificate of calibration (certificate with data is available for an additional charge).
Warranty:	3 years (see individual statement for further details)

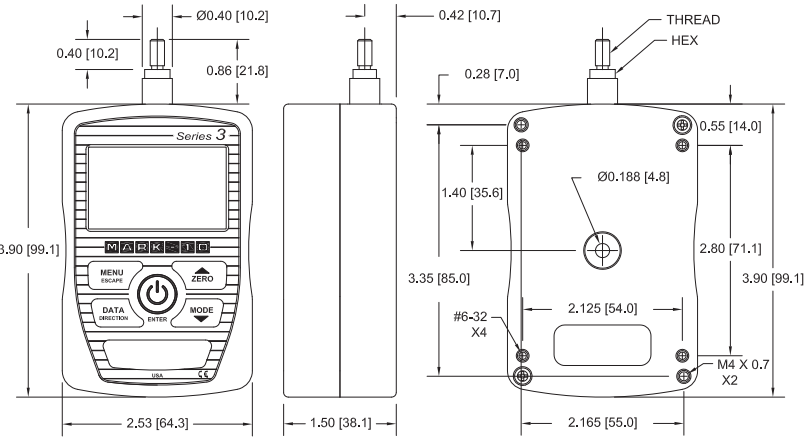

	Thread	Hex
M3-012 - M3-100	#10-32 UNF	5/16" [7.94 mm]
M3-200 - M3-500	5/16-18 UNC	11/32" [8.73 mm]

Capacity & Resolution

Model	Capacity				Resolution			
	lbF	kgF	gF	N	lbF	kgF	gF	N
M3-012	0.12		50	0.5	0.0001		0.05	0.0005
M3-025	0.25		100	1	0.0002		0.1	0.001
M3-05	0.5		250	2.5	0.0005		0.2	0.002
M3-2	2	1		10	0.002	0.001		0.01
M3-5	5	2.5		25	0.005	0.002		0.02
M3-10	10	5		50	0.01	0.005		0.05
M3-20	20	10		100	0.02	0.01		0.1
M3-50	50	25		250	0.05	0.02		0.2
M3-100	100	50		500	0.1	0.05		0.5
M3-200	200	100		1000	0.2	0.1		1
M3-500	500	250		2500	0.5	0.2		2



Specifications subject to change without prior notice

All models include 110V AC adapters, unless ordered as below:

Add suffix 'E' for euro plug (220V), 'U' for UK plug (220V) or 'A' for Australian plug (220V).

Example: M3-05E, M3-100U, M3-500A